

# WHAT IF WE RESTORE TO THE FUTURE? AN ALTERNATIVE CONCEPT OF DEADLOCK RECOVERY WITH PETRI NETS

**IWONA GROBELNA**



**25 MARCA 2026**

# **OUTLINE**

1. Introduction
2. Background
3. Concept description
4. Case study
5. Conclusion

# INTRODUCTION

**Petri nets** remain a well-established formalism for modelling flexible manufacturing systems.

Resource contention may lead to **deadlocks**.

Usually, recovery policies rely on rollback mechanisms.

We propose a backward and forward-looking deadlock recovery policy & introduce the concept of moving to an alternative state.

The proposed approach preserves the original state space.

The preliminary results indicate that **restore-to-the-future recovery** is a promising alternative to classical rollback-based methods.

# BACKGROUND

## MANUFACTURING SYSTEMS

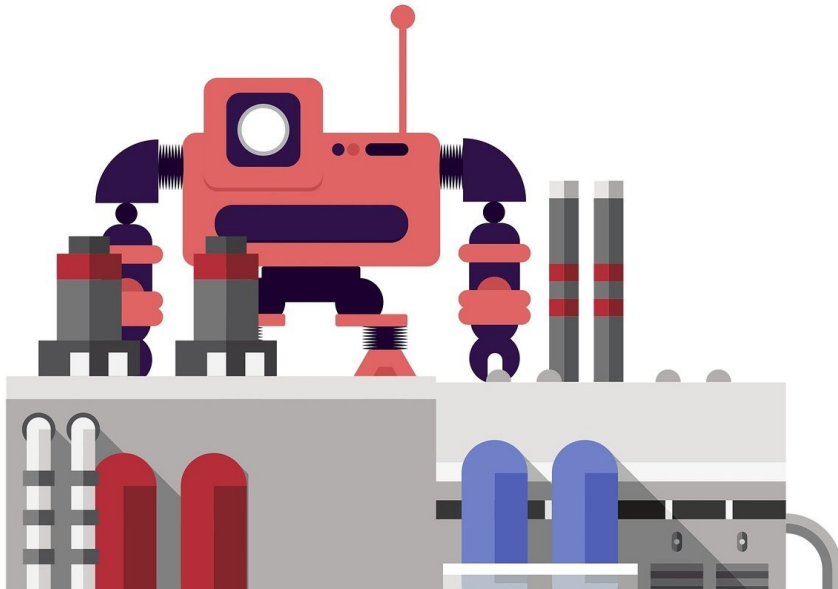

Modern manufacturing systems have advanced rapidly through Industry 4.0, 5.0 & 6.0.

They integrate technologies such as cloud computing, IoT, and AI to achieve smart, flexible, and circular production.

Key component of these systems is the **control layer**.

# BACKGROUND

## PETRI NETS

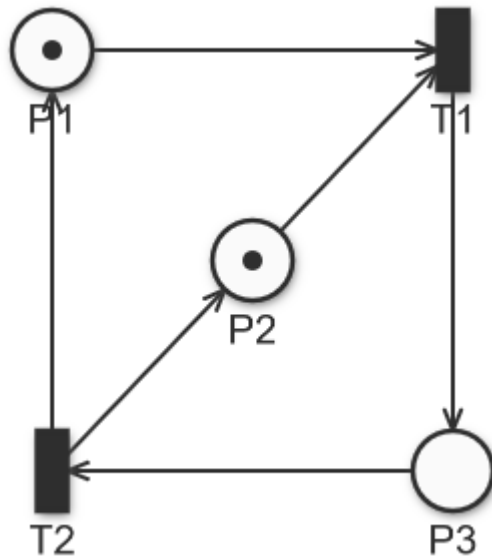

**Effective modelling** and **verification** framework.

Particularly suitable for modelling manufacturing systems involving sequential processes with shared resources.

Competition for shared resources can lead to deadlocks that stop the system's operation.

# BACKGROUND

## DEADLOCK MANAGEMENT



# BACKGROUND

## OUR DEADLOCK RECOVERY POLICIES SO FAR

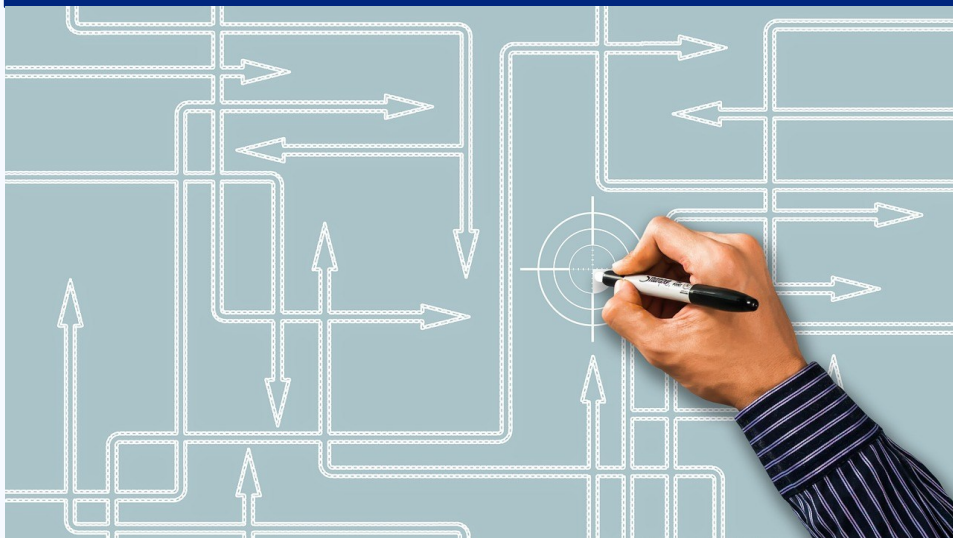

With minimized  
traversing within  
reachability  
graph

With exhaustive  
exploration of  
reachability  
graph

Process-  
oriented

Quick Heuristic

# CONCEPT DESCRIPTION

Simple, yet effective principle:

**Instead of limiting the system to rolling back to a previously reached legal state, it restores the execution to a future legal marking, avoiding the path leading to the deadlock.**

A reachability graph is analyzed (potentially costly for large-scale models).

The method identifies, for each deadlock marking, the closest previous legal marking and then the closest future legal marking that could have been reached from it.

Then, a transition is added that recovers from the deadlock to the legal marking identified in this way.

# CONCEPT DESCRIPTION

Before inserting any recovery transitions, all candidate legal markings are collected across all deadlocks, and the minimal set of recovery transitions is selected.

The newly added transitions do not create markings that are unreachable in the original net.

Main idea:

If a system is deadlocked, then at certain previous state it took a wrong turn, either directly to a deadlock or to a bad marking (inevitably leading to a deadlock).

# CASE STUDY

## CLASSICAL EXAMPLE WITH TWO PRODUCTION SEQUENCES

11 places, 8 transitions

Initial marking:

$$M_0 = (3p_1 + 3p_8 + p_9 + p_{10} + p_{11}).$$

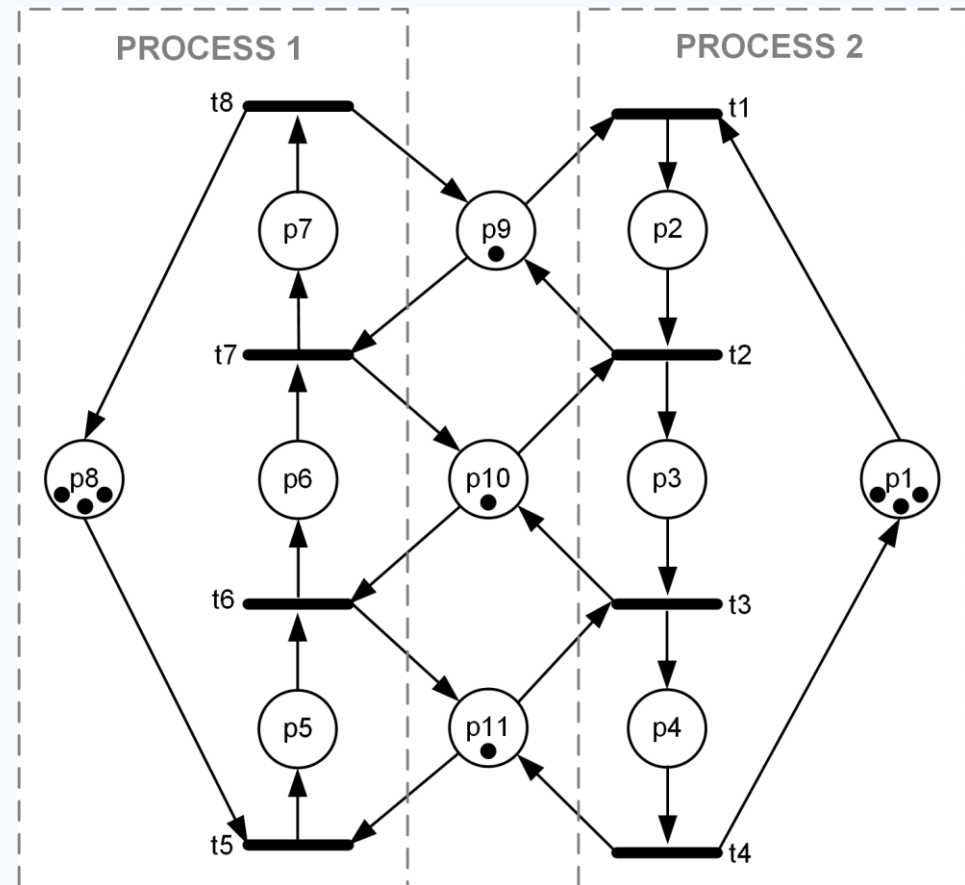

# CASE STUDY

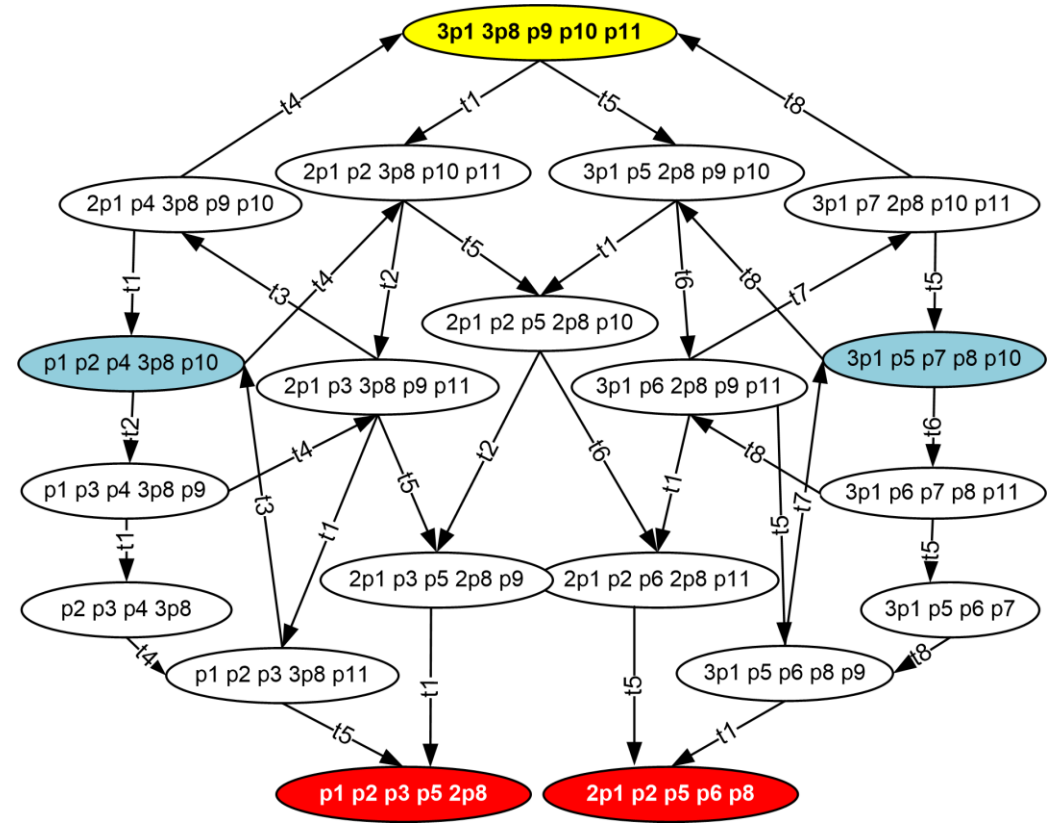
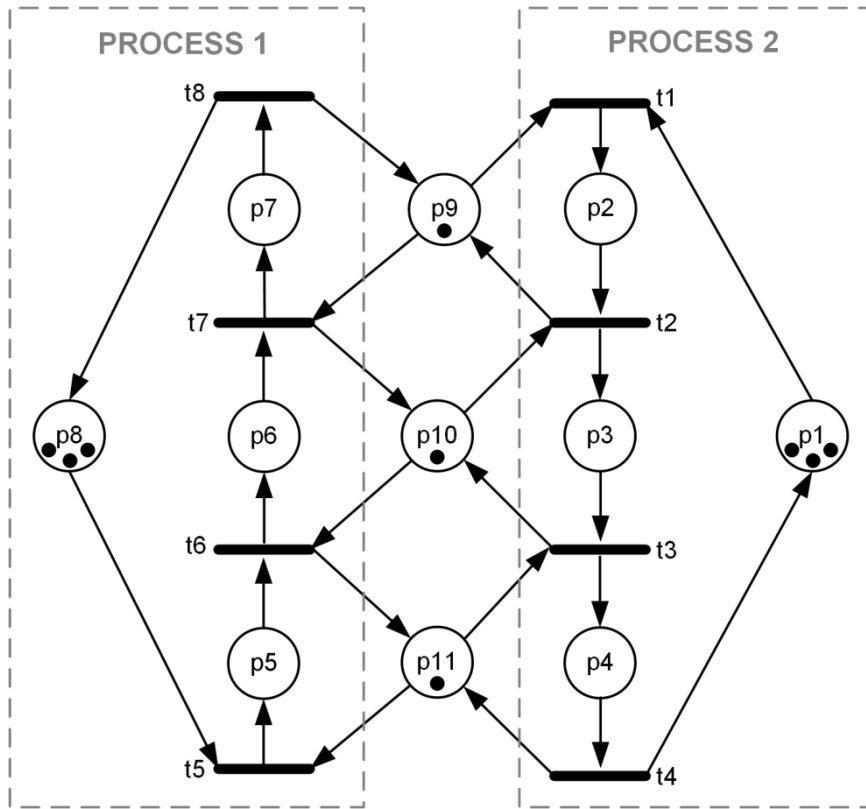

# CASE STUDY

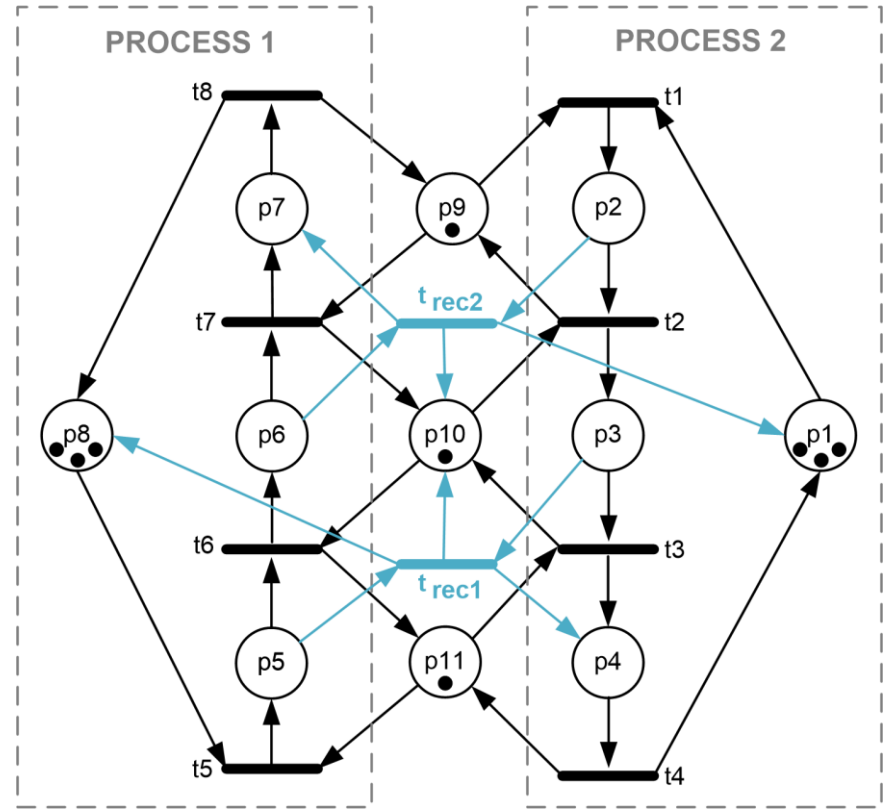
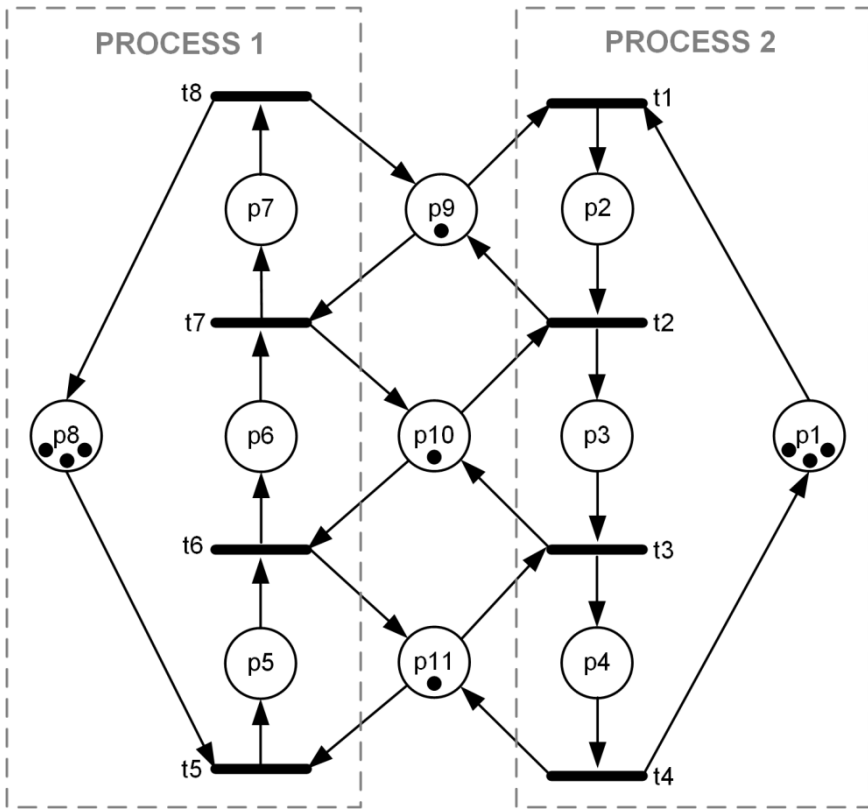

# CONCLUSION

We propose a **novel future-oriented policy of deadlock recovery** with Petri nets.

Instead of performing a pure rollback (restoring to a previous legal state), we propose a **backward and forward-looking** deadlock recovery policy.

A Petri net with deadlocks is augmented with transitions that move the system directly towards the desirable future states.

Although the full reachability graph needs to be constructed, there is no need to perform a deep search within it.

Further research plans... Maybe instead of using the reachability graph, the resource flow graphs could be used?

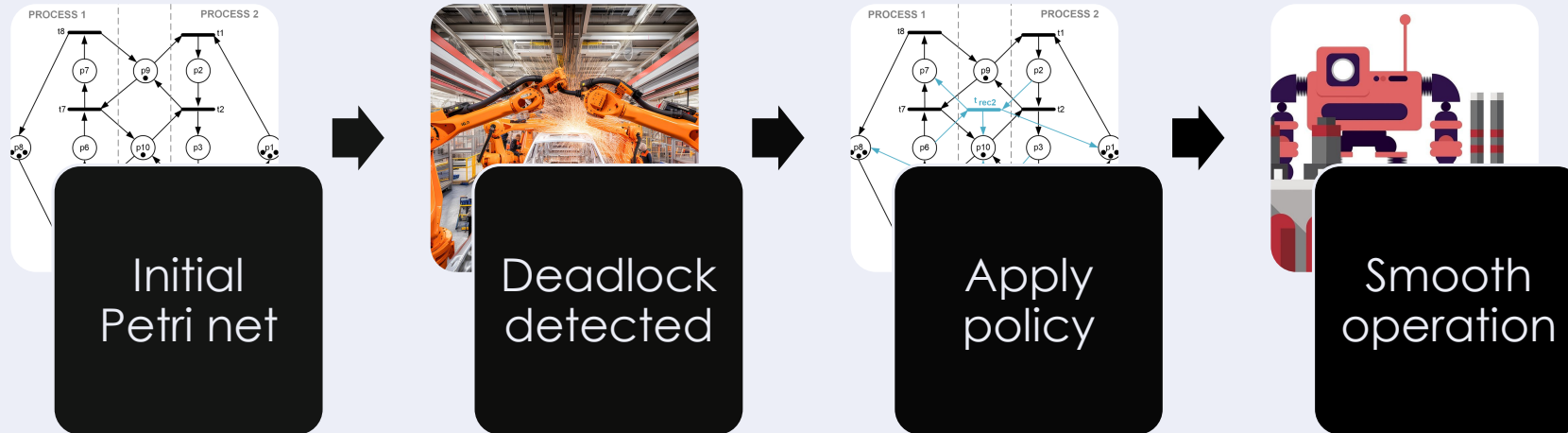

# Thank you for attention!

Based on a recent presentation at: 2026 25th International Symposium INFOTEH-JAHORINA, „What If We Restore to the Future? An Alternative Concept of Deadlock Recovery with Petri Nets”, Iwona Grobelna, Andrei Karatkevich